

18" ROUND RISER BLOCK

ITEM #A-17

WEIGHT - SEE CHART BELOW

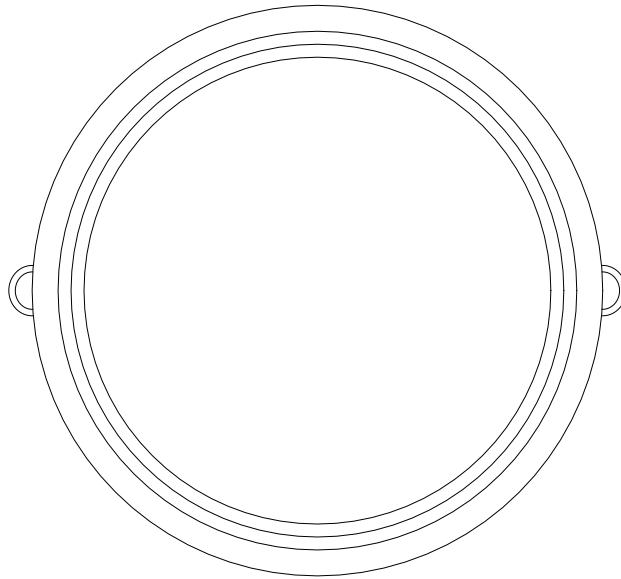

TOP VIEW

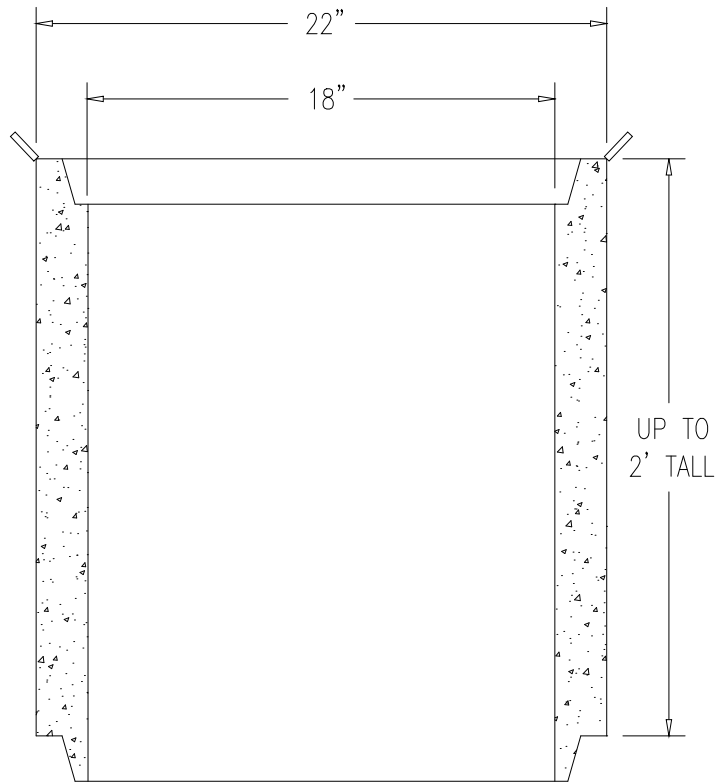

FRONT SECTION VIEW

DESIGN NOTES:

- 1 - CONCRETE 4000 PSI AT 28 DAYS.
- 2 - THIS ITEM IS A STANDARD RISER FOR OUR SEPTIC TANKS.

HEIGHT	WEIGHT	ITEM #
6"	65 LBS	A-1701
12"	130 LBS	A-1702
18"	195 LBS	A-1703
24"	260 LBS	A-1704