

"QUALITY PUMPS SINCE 1939"

Product information presented here reflects conditions at time of publication. Consult factory regarding discrepancies or inconsistencies.

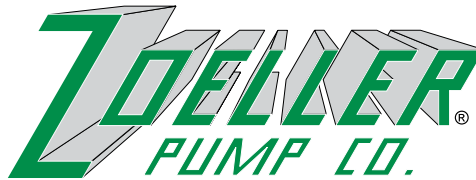

SECTION: 3.20.014

FM1919

1108

Supersedes

1206

MAIL TO: P.O. BOX 16347 • Louisville, KY 40256-0347
SHIP TO: 3649 Cane Run Road • Louisville, KY 40211-1961
(502) 778-2731 • 1 (800) 928-PUMP • FAX (502) 774-3624

visit our web site:
www.zoeller.com

ZOELLER ONSITE WASTEWATER PRODUCTS

INTRODUCING ZOELLER ONSITE "DOSE-MATE" PUMPS

COMPARE THESE FEATURES

- Durable cast iron construction.
- Model 151 comes standard with a glass-filled polypropylene base.
- Corrosion resistant powder coated epoxy finish.
- Stainless steel lifting handle.
- Assembled with stainless steel bolts.
- Non-clogging engineered thermoplastic vortex impeller design.
- Model 151 - 1/3 HP passes 1/2" spherical solids.
- Model 152 - .4 HP passes 3/4" spherical solids.
- Model 153 - 1/2 HP passes 3/4" spherical solids.
- Motor - 60 Hz, 3450 RPM, oil-filled, hermetically sealed, automatic reset thermal overload protected.
- Carbon/Ceramic seals.
- Upper sleeve bearing and lower ball bearing running in bath of oil.
- 20 ft. UL Listed power cord with molded 3-wire plug.
- 1 1/2" NPT vertical discharge.
- BN and BE standard models include a 20 ft. variable level float switch.
- Operates at temperatures to 130°F (54°C) in effluent applications.
- All models include a 1 1/2" x 2" PVC adapter fitting.

Note: The sizing of effluent systems normally requires variable level float(s) controls and properly sized basins to achieve required pumping cycles or dosing timers with nonautomatic pumps.

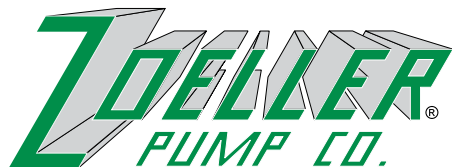

Manufacturers of . . .

"QUALITY PUMPS SINCE 1939"

151/152/153 EFFLUENT SERIES

(For Pump Prefix Identification see News & Views 0052)

"DOSE-MATE"

FOR SEPTIC TANK - LOW PRESSURE PIPE (LPP)
AND ENHANCED FLOW STEP SYSTEMS

EFFLUENT
SUBMERSIBLE

1 1/2" NPT DISCHARGE



Tested to UL Standard UL778
and Certified to CSA
Standard CSA22.2 No. 108



Model N152/N153
High Head
Effluent

MODELS AVAILABLE

- N151/N152/N153 & E151/E152/E153 nonautomatic
- BN151/BN152/BN153 & BE151/BE152/BE153 packaged with Piggyback Variable Level Float Switch
- 1/3, .4 & 1/2 HP, 1Ph 115V or 230V



POWDER
COATED
TOUGH™

Model BN152/BN153
High Head
Effluent

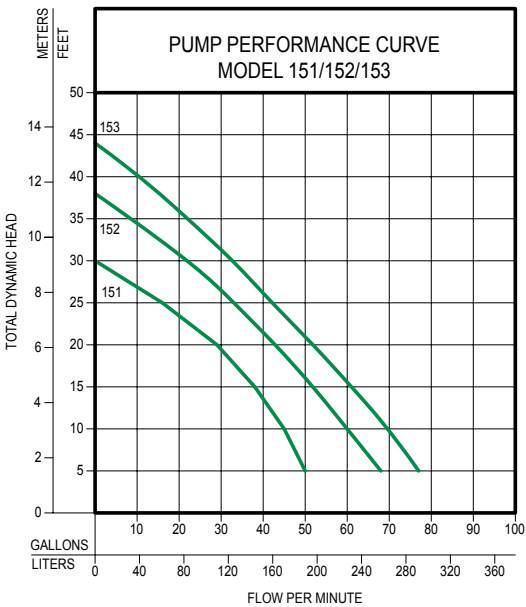

TOTAL DYNAMIC HEAD/FLOW
PER MINUTE
EFFLUENT AND DEWATERING

MODEL		151		152		153	
Feet	Meters	Gal.	Liters	Gal.	Liters	Gal.	Liters
5	1.5	50	189	69	261	77	291
10	3.0	45	170	61	231	70	265
15	4.6	38	144	53	201	61	231
20	6.1	29	110	44	167	52	197
25	7.6	16	61	34	129	42	159
30	9.1	--	--	23	87	33	125
35	10.7	--	--	--	--	22	85
40	12.2	--	--	--	--	11	42
Shut-off Head:		30 ft. (9.1m)		38 ft. (11.6m)		44 ft. (13.4m)	

014508B

CONSULT FACTORY FOR SPECIAL APPLICATIONS

- Timed dosing panels available.
- Electrical alternators, for duplex systems, are available and supplied with an alarm.
- Variable level control switches are available for controlling single phase systems.
- Double piggyback variable level float switches are available for variable level long and short cycle controls.
- Sealed Qwik-Box available for outdoor installations. See FM1420.
- Over 130°F (54°C) special quotation required.

151/152/153 Series

151/152/153 MODELS				Control Selection		
Model	Volts-Ph	Mode	Amps	Simplex	Duplex	
N151	115	1	Non	6.0	1	2 or 3
BN151	115	1	Auto	6.0	Included	2 or 3
E151	230	1	Non	3.2	1	2 or 3
BE151	230	1	Auto	3.2	Included	2 or 3
N152	115	1	Non	8.5	1	2 or 3
BN152	115	1	Auto	8.5	Included	2 or 3
E152	230	1	Non	4.3	1	2 or 3
BE152	230	1	Auto	4.3	Included	2 or 3
N153	115	1	Non	10.5	1	2 or 3
BN153	115	1	Auto	10.5	Included	2 or 3
E153	230	1	Non	5.3	1	2 or 3
BE153	230	1	Auto	5.3	Included	2 or 3

SELECTION GUIDE

1. Single piggyback variable level float switch or double piggyback variable level float switch. Refer to FM0477.
2. See FM0712 for correct model of Electrical Alternator E-Pak.
3. Variable level control switch 10-0743 used as a control activator, specify duplex (3) or (4) float system.

CAUTION

All installation of controls, protection devices and wiring should be done by a qualified licensed electrician. All electrical and safety codes should be followed including the most recent National Electrical Code (NEC) and the Occupational Safety and Health Act (OSHA).

Model 151

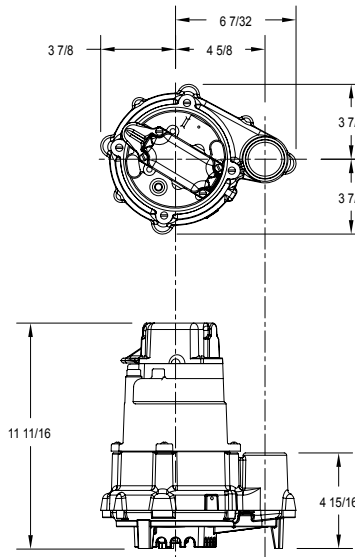

SK2444

Models 152 / 153

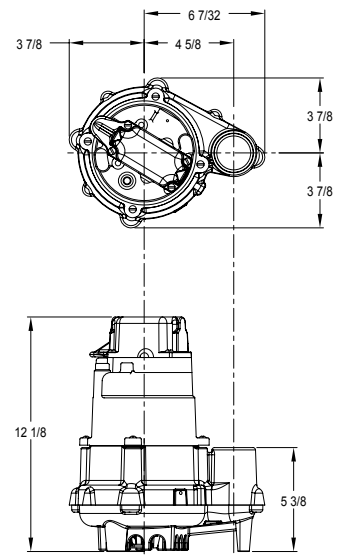

SK2064

"Easy assembly"
(pump & discharge pipe not included.)

OPTIONAL PUMP STAND P/N 10-2213

- Reduces potential clogging by debris.
- Replaces rocks or bricks under the pump.
- Made of durable, noncorrosive ABS.
- Raises pump 2" off bottom of basin.
- Provides the ability to raise intake by adding sections of 1½" or 2" PVC piping.
- Attaches securely to pump.
- Accommodates sump, dewatering and effluent applications.

NOTE: Make sure float is free from obstruction.

RESERVE POWERED DESIGN

For unusual conditions a reserve safety factor is engineered into the design of every Zoeller pump.